

<sup>®</sup>  
MACKIE

# SWA1501 ACTIVE SUBWOOFER SYSTEM USER'S MANUAL

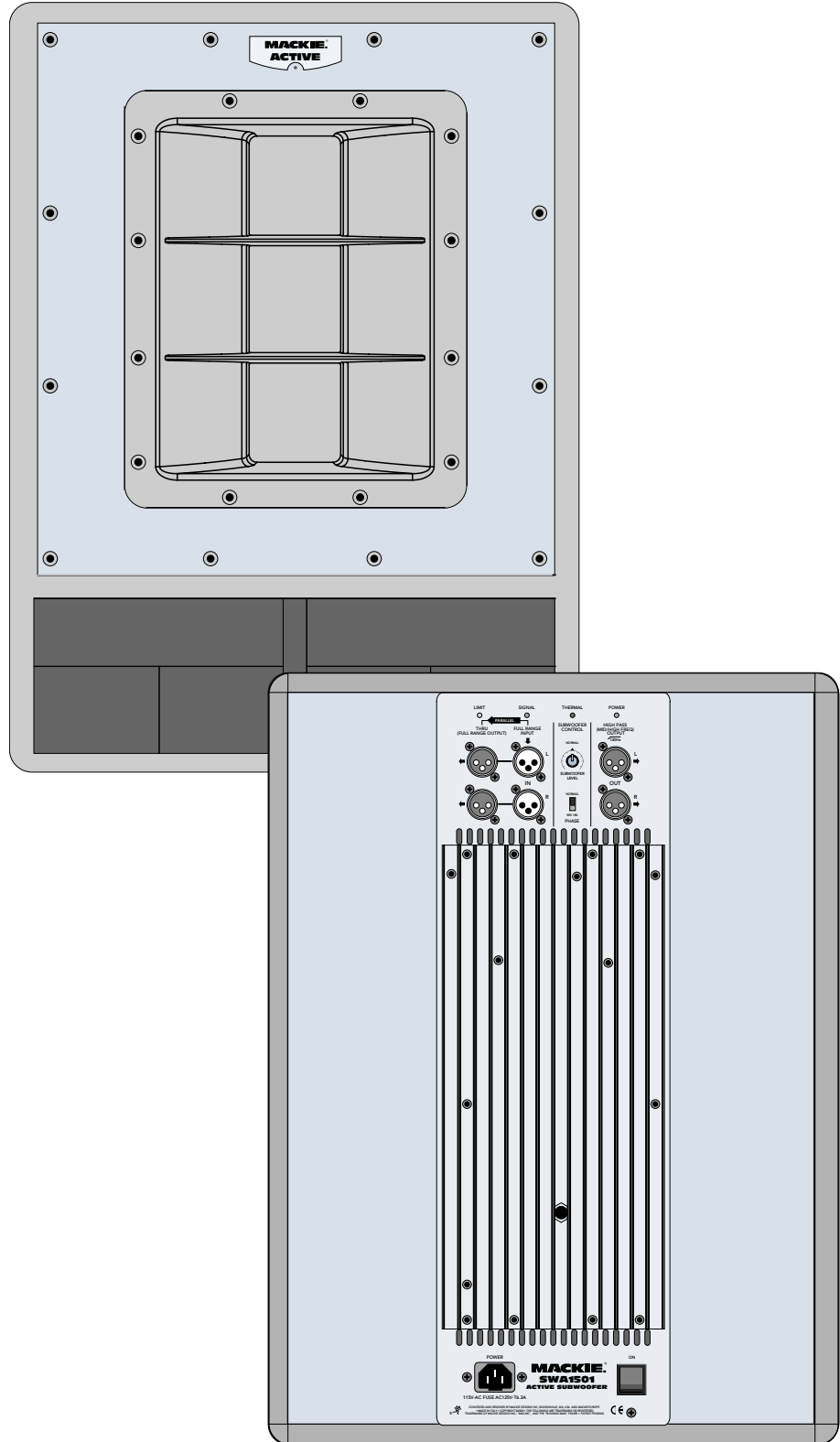

 <div style="display: inline-block; background-color: black; color: white; padding: 2px 10px; font-weight: bold; font-size: 1.2em;">CAUTION AVIS</div> 
<p><b>RISK OF ELECTRIC SHOCK DO NOT OPEN</b></p> <p><b>RISQUE DE CHOC ELECTRIQUE NE PAS OUVRIR</b></p>
<p><b>CAUTION: TO REDUCE THE RISK OF ELECTRIC SHOCK DO NOT REMOVE COVER (OR BACK) NO USER-SERVICEABLE PARTS INSIDE REFER SERVICING TO QUALIFIED PERSONNEL</b></p> <p><b>ATTENTION: POUR EVITER LES RISQUES DE CHOC ELECTRIQUE, NE PAS ENLEVER LE COUVERCLE. AUCUN ENTRETIEN DE PIECES INTERIEURES PAR L'USAGER. CONFIER L'ENTRETIEN AU PERSONNEL QUALIFIE.</b></p> <p><b>AVIS: POUR EVITER LES RISQUES D'INCENDIE OU D'ELECTROCUTION, N'EXPOSEZ PAS CET ARTICLE A LA PLUIE OU A L'HUMIDITE</b></p>



The lightning flash with arrowhead symbol within an equilateral triangle is intended to alert the user to the presence of uninsulated "dangerous voltage" within the product's enclosure that may be of sufficient magnitude to constitute a risk of electric shock to persons.

*Le symbole éclair avec point de flèche à l'intérieur d'un triangle équilatéral est utilisé pour alerter l'utilisateur de la présence à l'intérieur du coffret de "voltage dangereux" non isolé d'ampleur suffisante pour constituer un risque d'électrocution.*



The exclamation point within an equilateral triangle is intended to alert the user of the presence of important operating and maintenance (servicing) instructions in the literature accompanying the appliance.

*Le point d'exclamation à l'intérieur d'un triangle équilatéral est employé pour alerter les utilisateurs de la présence d'instructions importantes pour le fonctionnement et l'entretien (service) dans le livret d'instruction accompagnant l'appareil.*

## SAFETY INSTRUCTIONS

- 1. Read Instructions** — All the safety and operation instructions should be read before this Mackie product is operated.
  - 2. Retain Instructions** — The safety and operating instructions should be kept for future reference.
  - 3. Heed Warnings** — All warnings on this Mackie product and in these operating instructions should be followed.
  - 4. Follow Instructions** — All operating and other instructions should be followed.
  - 5. Water and Moisture** — This Mackie product should not be used near water — for example, near a bathtub, washbowl, kitchen sink, laundry tub, in a wet basement, near a swimming pool, swamp or salivating St. Bernard dog, etc.
  - 6. Cleaning** — Clean only with a dry cloth.
  - 7. Ventilation** — This Mackie product should be situated so that its location or position does not interfere with its proper ventilation. For example, the Component should not be situated on a bed, sofa, rug, or similar surface that may block any ventilation openings, or placed in a built-in installation such as a bookcase or cabinet that may impede the flow of air through ventilation openings.
  - 8. Heat** — This Mackie product should be situated away from heat sources such as radiators, or other devices which produce heat.
- WARNING:** The heat sink may reach high temperatures during standard use. To ensure proper operation, allow a minimum of six inches of clearance from the heat sink surface and adequate ventilation.

**9. Power Sources** — This Mackie product should be connected to a power supply only of the type described in these operation instructions or as marked on this Mackie product.

**10. Power Cord Protection** — Power supply cords should be routed so that they are not likely to be walked upon or pinched by items placed upon or against them, paying particular attention to cords at plugs, convenience receptacles, and the point where they exit this Mackie product.

**11. Object and Liquid Entry** — Care should be taken so that objects do not fall on, and liquids are not spilled into, this Mackie product.

**12. Damage Requiring Service** — This Mackie product should be serviced only by qualified service personnel when:

- A.** The power-supply cord or the plug has been damaged; or
- B.** Objects have fallen, or liquid has spilled into this Mackie product; or
- C.** This Mackie product has been exposed to rain; or
- D.** This Mackie product does not appear to operate normally or exhibits a marked change in performance; or
- E.** This Mackie product has been dropped, or its chassis damaged.

**13. Servicing** — The user should not attempt to service this Mackie product beyond those means described in this operating manual. All other servicing should be referred to the Mackie Service Department.

**14.** To prevent electric shock, do not use this polarized plug with an extension cord, receptacle or other outlet unless the blades can be fully inserted to prevent blade exposure.

*Pour prévenir les chocs électriques ne pas utiliser cette fiche polarisée avec un prolongateur, un prise de courant ou une autre sortie de courant, sauf si les lames peuvent être insérées à fond sans laisser aucune partie à découvert.*

**15. Grounding or Polarization** — Precautions should be taken so that the grounding or polarization means of this Mackie product is not defeated.

**16. Power Precaution** — Unplug this Mackie product during lightning storms or when unused for long periods of time. Note that this Mackie product is not completely disconnected from the AC mains service when the power switch is in the OFF position.

**17.** This apparatus does not exceed the Class A/Class B (whichever is applicable) limits for radio noise emissions from digital apparatus as set out in the radio interference regulations of the Canadian Department of Communications.

*ATTENTION — Le présent appareil numérique n'émet pas de bruits radioélectriques dépassant les limites applicables aux appareils numériques de class A/de class B (selon le cas) prescrites dans le règlement sur le brouillage radioélectrique édicté par les ministere des communications du Canada.*

**WARNING** — To reduce the risk of fire or electric shock, do not expose this appliance to rain or moisture.

**WARNING** — The cabinet has no rigging points and is not suitable for flying. Never attempt to suspend the cabinet by its handles.



## Lend Me Your Ears

Exposure to extremely high noise levels may cause permanent hearing loss. Individuals vary considerably in susceptibility to noise-induced hearing loss, but nearly everyone will lose some hearing if exposed to sufficiently intense noise for a period of time. The U.S. Government's Occupational Safety and Health Administration (OSHA) has specified the permissible noise level exposures shown in this chart.

According to OSHA, any exposure in excess of these permissible limits could result in some hearing loss. To ensure against potentially dangerous exposure to high sound-pressure levels, it is recommended that all persons exposed to equipment capable of producing these levels use hearing protectors while this unit is in operation. Ear plugs or protectors in the ear canals or over the ears must be worn when operating this amplification system in order to prevent a permanent hearing loss if exposure is in excess of the limits set forth here.

<b>Duration Per Day In Hours</b>	<b>Sound Level dBA, Slow Response</b>	<b>Typical Example</b>
8	90	Duo in small club
6	92	
4	95	Subway Train
3	97	
2	100	Very loud classical music
1.5	102	
1	105	Patrice screaming at Ron about deadlines
0.5	110	
0.25 or less	115	Loudest parts at a rock concert



The SWA1501 can produce a maximum SPL of 128 dB @ 1m

## CONTENTS

Lend Me Your Ears .....	3
INTRODUCTION .....	3
REAR PANEL DESCRIPTION .....	4
HOOKUP DIAGRAMS .....	5
CONNECTIONS .....	6
PLACEMENT .....	6
AC POWER .....	7

THERMAL CONSIDERATIONS .....	7
SERVICE INFORMATION .....	7
Warranty Service .....	7
Troubleshooting .....	7
Repair .....	9
SWA1501 SPECIFICATIONS .....	10
Architect's and Engineer's Specifications .....	10
Frequency Response .....	11
Dimensions .....	11

## INTRODUCTION

Thank you for choosing Mackie Designs' active sound reinforcement speaker systems.

The SWA1501 is a high output active subwoofer system. It features a high-precision 15" transducer combined with application-specific amplifier technology. The system is composed of a single, compact subwoofer cabinet with built-in control and amplifier electronics.

Connecting and setting up the SWA1501 is a breeze. It accepts a stereo or mono line-level signal via female XLR input jacks. Male XLR Thru jacks are provided for daisy-chaining the signal to additional SWA1501 cabinets. The built-in crossover separates the low frequencies from the high frequencies, and routes the high frequencies to the male XLR high-pass output jacks. Connect these to the inputs of full-range active speakers such as the Mackie Designs SRM450s, or to an amplifier powering a pair of passive speakers such as the combination of

Mackie Designs M•1400i and C300s. A Phase switch gives you the option of reversing the polarity of the signal to the subwoofer by 180°. A Subwoofer Level control allows you to adjust the balance between the subwoofer and the full-range speakers.

The built-in amplifier produces 500 watts of continuous power. The amplifier module sits on a heatsink that eliminates the need for fans, dramatically extending life expectancy, and eliminating maintenance cycles. A tremendous benefit of having the amplifier located within the subwoofer cabinet is that the SWA1501 functions as a system, optimizing acoustic, electronic, and mechanical designs to achieve the highest level of performance and value.

The cabinet is constructed with 15mm thick multi-layered birch plywood. Carrying handles are integrated into each side for easy loading and transport.

Don't forget to visit our website at [www.mackie.com](http://www.mackie.com) for more information about this and other Mackie products.



# REAR PANEL DESCRIPTION

## 1 POWER Switch

Use this switch to turn the SWA1501 on and off. Make sure the signal source's level control is turned down before you turn it on.

## 2 AC Receptacle

This is where you connect the AC line-cord to provide AC power to the SWA1501's built-in power amplifiers. Plug the linecord into an AC socket properly configured for your particular model.

## 3 LIMIT Indicator

The SWA1501 has a built-in limiter that prevents the amplifier outputs from overdriving the transducers. The LIMIT indicator lights when the limiter is activated. It's okay for the LIMIT indicator to blink occasionally, but if it blinks frequently or lights continuously, turn down the level control until the LIMIT indicator only blinks occasionally.

## 4 SIGNAL Present Indicator

This LED illuminates whenever there is a signal present at the FULL RANGE INPUT connector on the rear panel.

## 5 THERMAL Indicator

The SWA1501 has a thermal protection circuit that monitors the internal temperature of the amplifiers and heatsink. If the internal temperature should exceed a safe operating level, this indicator lights and the signal is muted to allow the amplifier to cool. When the temperature cools to a safe level once again, the thermal protection circuit deactivates and normal operation continues.

**Note:** Activation of the thermal protection circuit is an indication that you should take steps to avoid continued thermal problems. See "Thermal Considerations" on page 7.

## 6 POWER Indicator

When the POWER switch is turned on and the linecord is connected to an active

AC power supply, this indicator lights green to let you know that you're ready to rock and roll. The cool blue LED on the front of the cabinet works in the same way.

## 7 FULL RANGE INPUT

These are female XLR-type connectors that accept a balanced line-level signal from a mixing console or other signal source.

## 8 THRU (FULL RANGE OUTPUT)

These are male XLR-type connectors that produce exactly the same signal that is connected to the FULL RANGE INPUT jack. Use it to daisy-chain several SWA1501s together off the same signal source.

## 9 HIGH PASS (MID/HIGH FREQ) OUTPUT

These are male XLR-type connectors that produce the frequencies above 120Hz. Connect these to a pair of full-range active speakers or to an amplifier/passive speaker combination. The SWA1501 reproduces the frequencies below 120Hz.

## 10 SUBWOOFER LEVEL Control

This adjusts the subwoofer level. The center detent position provides 15 dB of headroom with a nominal +4 dBu input signal. Use this as a starting point for setting the balance between the subwoofer and the main speakers.

## 11 PHASE

This switch reverses the polarity of the system. Depending on the placement of the SWA1501 subwoofer relative to the full-range speakers, you may get a better low-frequency response in the room if you reverse the polarity of the subwoofer's signal. Experiment with this switch to determine which position sounds best.

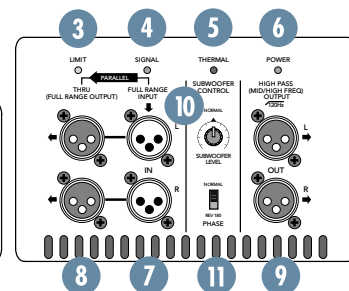

# HOOKUP DIAGRAMS

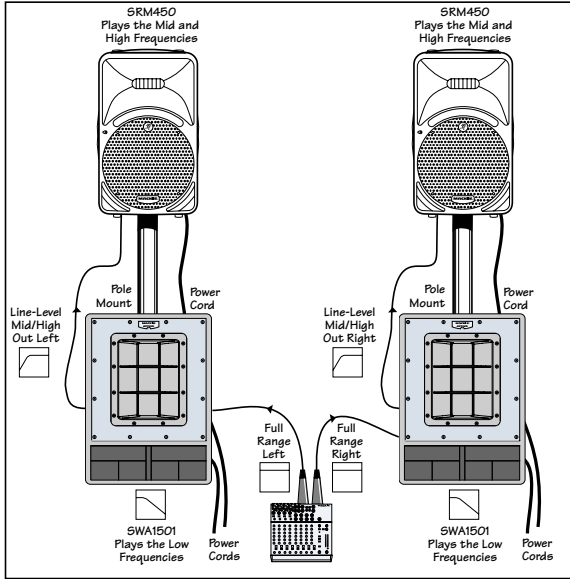

**2 SWA1501s WITH 2 SRM450s**

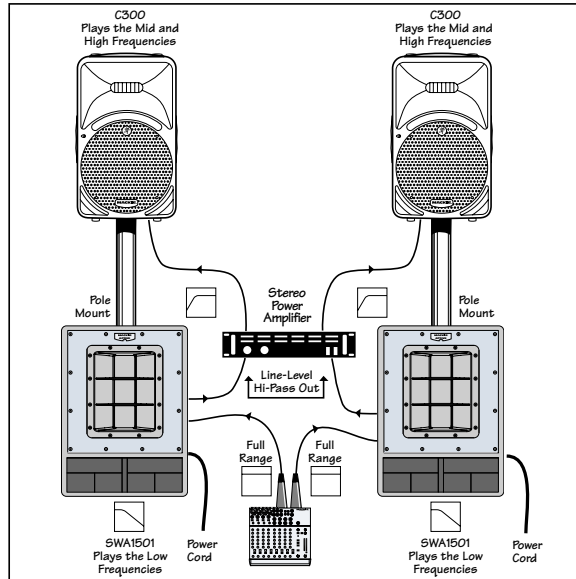

**2 SWA1501s WITH STEREO AMPLIFIER AND 2 C300s**

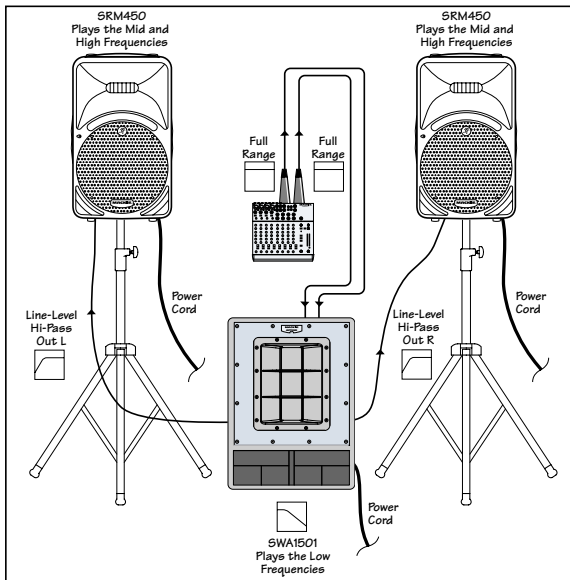

**1 SWA1501 WITH 2 SRM450s**

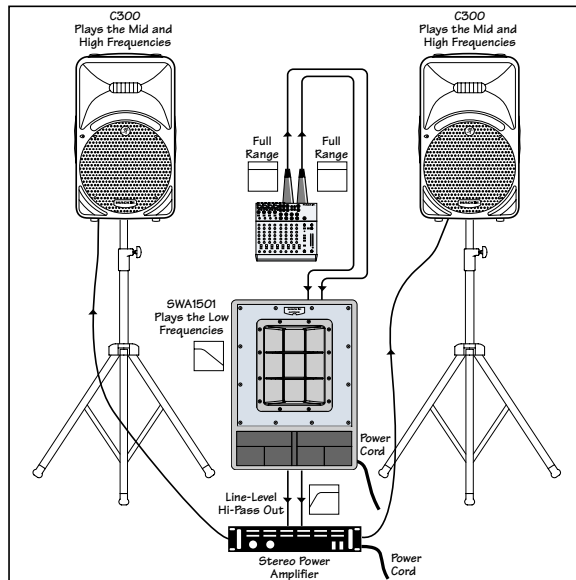

**1 SWA1501 WITH STEREO AMPLIFIER AND 2 C300s**

## CONNECTIONS

The SWA1501 has two female XLR inputs that accept a balanced line-level signal. When connecting a balanced signal, be sure it's wired per AES (Audio Engineering Society) standards:

<b>XLR</b>	
Hot (+)	Pin 2
Cold (-)	Pin 3
Shield (Ground)	Pin 1

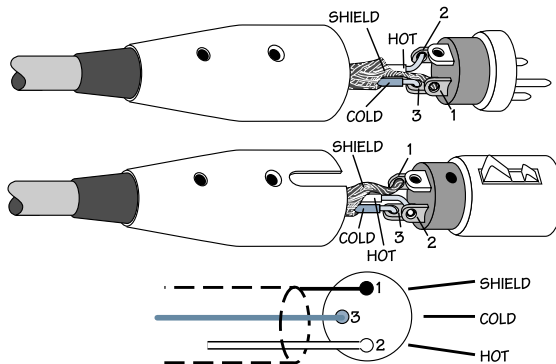

### Balanced XLR Connectors

If connecting an unbalanced signal to the SWA1501 balanced input, be sure that the signal high (hot) connection is wired to Pin 2 and the unbalanced ground connection is wired to the low *and* the ground connections of the balanced input (Pins 3 and 1). If there are ground-loop problems, try connecting the unbalanced ground connection only to the input low connection (Pin 3), and leaving the input ground connection disconnected.

There are also four male XLR connectors labeled THRU (FULL RANGE OUTPUT) and HIGH PASS (MID/HIGH FREQ) OUTPUT. These are also wired according to the AES standard.

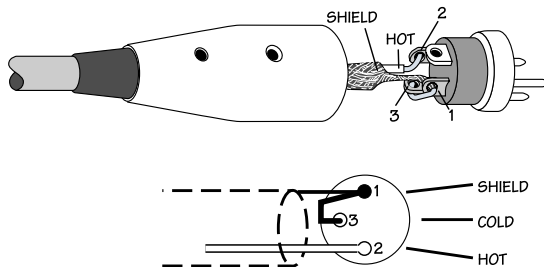

### Unbalanced Male XLR Connector

The THRU output connectors allow you to connect more than one SWA1501 to your system. Simply plug the signal source (i.e., mixer output) into the first speaker's FULL RANGE INPUT jacks, and patch that speaker's THRU jacks to the next speaker's INPUT jacks, and so on, daisy-chaining multiple speakers.

The THRU jack is wired straight from the FULL RANGE INPUT connector — there is no electronic circuitry between — so the signal coming out of the THRU jack is exactly the same as the signal going in.

The HIGH PASS OUTPUT jacks provide a line-level signal of the frequencies above 120Hz that you connect to a pair of active speakers (or to a stereo amplifier powering a pair of passive speakers). See the diagrams on the rear panel of the SWA1501 for additional connection information.

## PLACEMENT

The SWA1501 subwoofer is designed to sit on the floor or on sturdy stands.

A socket is provided on the top of the SWA1501 for mounting the Mackie SRM450 active speaker. Use the optional Mackie speaker mounting pole to mount the SRM450 on the SWA1501 (see Hookup Diagram on page 5).

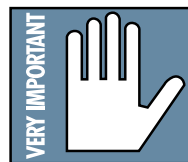

As with any powered components, protect the SWA1501s from exposure to moisture. If you are setting them up outdoors, make sure they are under cover if you expect rain.



**WARNING:** The cabinet has no rigging points and is not suitable for rigging. **NEVER** attempt to suspend the SWA1501 by its handles.

## AC POWER

Be sure the SWA1501 is plugged into an outlet that is able to supply the correct voltage specified for your model. If the voltage should drop below 97% of the specified line voltage, the built-in amplifiers will no longer be able to supply rated power. (They will continue to operate down to 80% of the rated line voltage, but won't reach full power, resulting in lower headroom.)

Be sure the electrical service can supply enough amperage for all the components connected to it.

We recommend that a stiff (robust) supply of AC power be used because the amplifiers place high current demands on the AC line. The more power that is available on the line, the louder the speakers will play and the more peak output power will be available for cleaner, punchier bass. A suspected problem of "poor bass performance" is often caused by a weak AC supply to the amplifiers.



Never remove the ground pin on the power cord of the SWA1501 or any other component. This is very dangerous.

## THERMAL CONSIDERATIONS

The SWA1501 has a powerful 500 watt amplifier built-in. As amplifiers produce heat, it is important to dissipate the heat as quickly as possible. This results in increased reliability and longevity for the amplifier.

The amplifier module is mounted on a large heatsink, which is cooled by convection where cool air is drawn through its fins, carrying the heat away. In order for this convection cooling to work efficiently, it is important to provide adequate airspace behind the loudspeaker. When you position the SWA1501, we recommend leaving at least six inches of air space behind it.

In the unlikely event of the amplifier overheating, a built-in thermal switch will activate, which mutes the signal. When the amplifier has cooled down to a safe operating temperature, the thermal switch resets itself, and the SWA1501 resumes normal operation.

If the thermal switch activates frequently, try turning down the level control a notch or two on the mixing console (or other signal source) or on the subwoofer itself to avoid overheating the amplifiers.

If the temperature in the room is too high, it could cause the amplifier to overheat. In this case, you should try aiming a fan at the rear panel to move more air across the heatsink panel.

## SERVICE INFORMATION

### Warranty Service

If you think your subwoofer has a problem, please do everything you can to confirm it before calling for service, including reading through the following Troubleshooting section. Doing so might save you from being deprived of your Mackie loudspeaker.

Of all Mackie products returned for service (which is hardly any at all), many are coded "CND" — Could Not Duplicate— which usually means the problem lay somewhere else in the system. The following troubleshooting tips may sound obvious, but here are some things you can check:

### Troubleshooting

#### No power

- Our favorite question: Is it plugged in? Make sure the AC outlet is live (check with a tester or lamp).
- Our next favorite question: Is the POWER switch on? If not, try turning it on.
- Is the POWER LED on the rear panel glowing green? If not, make sure the AC outlet is live. If so, refer to "No sound" next.
- The internal AC line fuse may be blown. This is not a user serviceable part. If you suspect the AC line fuse is blown, please see the "Repair" section on page 9.

### No sound

- Is the input LEVEL control for the input source or the subwoofer turned all the way down? Verify that all the volume controls in the system are properly adjusted.
- Is the signal source working (and making union scale)? Make sure the connecting cables are in good repair and securely connected at both ends. Make sure the output volume (gain) control on the mixing console is turned up sufficiently to drive the inputs of the speaker.
- Make sure the mixer does not have a Mute on or a Processor loop engaged. If you find something like this, make sure the volume/gain is turned down before disengaging the offending switch.
- Is the thermal protection circuit activated? Make sure there is at least six inches of free space behind the SWA1501.

### Poor bass performance

- Check the polarity of the connections between the mixer and the loudspeakers. You may have your positive and negative connections reversed at one end of one cable, causing one loudspeaker to be out-of-phase.
- Try switching the PHASE switch on the rear panel. This affects the polarity between the full-range speakers and the SWA1501 and may improve the low-frequency response.

### Poor sound

- Is it loud and distorted? Make sure that you're not overdriving a stage in the signal chain. Verify that all level controls are set properly.
- Is the input connector plugged completely into the jack? Be sure all connections are secure. It's a good idea to periodically clean all electrical connections with a non-lubricating electrical contact cleaner.

### Noise

- Make sure all connections to the active loudspeakers are good and sound.
- Make sure none of the signal cables are routed near AC cables, power transformers, or other EMI-inducing devices.
- Is there a light dimmer or other SCR-based device on the same AC circuit as the SWA1501? Use an AC line filter or plug the SWA1501 into a different AC circuit.

### Hum

- Try disconnecting the cable connected to the INPUT jack. If the noise disappears, it could be a "ground loop," rather than a problem with the SWA1501. Try some of the following troubleshooting ideas:
- Use balanced connections throughout your system for the best noise rejection.
- Whenever possible, plug all the audio equipment's linecords into outlets which share a common ground. The distance between the outlets and the common ground should be as short as possible.



## Repair

Service for the SWA1501 is available only from one of our authorized domestic service stations or at the factory service center located in Whitinsville, Massachusetts. Service outside the United States can be obtained through local dealers or distributors.

If your SWA1501 needs service, please follow these instructions:

1. Review the preceding troubleshooting suggestions. Please.
2. Call Tech Support at 1-800-258-6883, 7am to 5pm PST, to explain the problem in detail. They will ask you all sorts of impertinent questions in the hope of sorting out the problem. If it appears that the SWA1501 needs repair, request an RA (Return Authorization) number. Have your subwoofer's serial number ready. You must have an RA number before you can obtain service at the factory or an authorized service center.
3. Keep this user's manual. We don't need it to repair the subwoofer.
4. Pack the subwoofer in its original packaging, including protective wrap, endcaps, and box. This is very important. When you call for the RA number, please let Tech Support know if you need new packaging. *Mackie is not responsible for any damage that occurs due to non-factory packaging.*
5. Include a legible note stating your name, shipping address (no P.O. boxes), daytime phone number, RA number, and a detailed description of the problem, including how we can duplicate it.
6. Write the RA number in **BIG PRINT** on top of the box.
7. Ship the subwoofer to us. We suggest insurance for all forms of cartage. Ship to this address:  
  

Mackie Designs  
SERVICE DEPARTMENT  
One Main Street  
Whitinsville, MA 01588
8. We'll try to fix the subwoofer in three to five business days. Ask Tech Support for current turnaround times when you call for your RA number. Once it is repaired, we'll ship it back the same way in which it was received. This paragraph does not necessarily apply to non-warranty service.



# SWA1501 SPECIFICATIONS

## System Specifications

<i>Frequency Range (-10 dB):</i>	36 Hz–120 Hz
<i>Frequency Response (-3 dB):</i>	47 Hz–120 Hz
<i>Maximum SPL @ 1m:</i>	125 dB
<i>Peak Output @ 1m:</i>	128 dB
<i>Crossover Frequency:</i>	120 Hz (12 dB/octave)
<i>Input Type:</i>	Balanced differential
<i>Input Impedance:</i>	50k ohms
<i>Input Protection:</i>	Level protected
<i>Thermal Protection:</i>	Input stage muting, auto-reset

## Transducer Specifications

### Low-Frequency Transducer

<i>Diameter:</i>	15" (380 mm)
<i>Voice Coil Diameter:</i>	3" (75 mm)

## Power Amplifier

### Low-Frequency Power Amplifier

<i>Rated Power*:</i>	500 watts RMS
<i>Rated THD:</i>	< 0.03 %
<i>Cooling:</i>	Passive

## Line Input Power

<i>US:</i>	120 VAC, 60Hz
<i>Recommended Amperage Service:</i>	8 A
<i>Europe:</i>	230 VAC, 50Hz
<i>Recommended Amperage Service:</i>	4 A

## Architect's and Engineer's Specifications

The active subwoofer loudspeaker system shall incorporate one 15-inch low-frequency (LF) transducer mounted within a vented enclosure and tuned for optimum low-frequency response. System frequency response shall vary no more than  $\pm 3$  dB from 47 Hz to 120 Hz measured on axis. The loudspeaker shall incorporate a low-frequency amplifier system capable of delivering 500 watts RMS over a frequency range of 30Hz to 150Hz. The system shall provide 125 dB of continuous output and 128 dB of peak output. The amplifier system shall be mounted on an aluminum heat sink, which shall be mounted on the rear of the enclosure, and shall be convection cooled.

The rear-mounted amplifier assembly shall comprise separate signal and AC power panels separated by a large aluminum heat sink. The signal input panel shall contain two input and two loop-through XLR connectors, two high-pass output XLR connectors, a volume level control, a phase switch, and four status LEDs for Power ON, Signal Present, Limit, and Thermal functions. The system shall accept a stan-

## Physical Properties

<i>Height:</i>	23.5" (597 mm)
<i>Width:</i>	17.2" (436 mm)
<i>Depth:</i>	23.7" (603 mm)
<i>Weight:</i>	88 lbs. (40 kg)
<i>Enclosure:</i>	15 mm thick multi-layered baltic birch wood
<i>Enclosure Geometry:</i>	Rectangular
<i>Mounting Methods:</i>	Floor mount only

**WARNING:** The cabinet has no rigging points and is not suitable for rigging. **NEVER** attempt to suspend the SWA1501 by its handles.

\* Rated power into loudspeaker's rated impedance.

## Disclaimer

Since we are always striving to make our products better by incorporating new and improved materials, components, and manufacturing methods, we reserve the right to change these specifications at any time without notice.

"Mackie" and the "Running Man" figure are trademarks or registered trademarks of Mackie Designs Inc.

All other brand names mentioned are trademarks or registered trademarks of their respective holders, and are hereby acknowledged.

©2003 Mackie Designs Inc.  
All Rights Reserved.  
Printed in the U.S.A.

Standard line-level signal via the XLR input connectors. The power switch and IEC AC connector shall be located on the power panel.

Thermal protection shall be provided by a heat sink-mounted thermal sensor, which monitors the heat sink temperature and triggers the thermal protection circuit should the temperature exceed 140° F (60° C). The Thermal LED shall light and the input signal shall be muted until the heat sink cools to a safe operating temperature, at which point the thermal protection circuit auto-resets and normal operation resumes.

Overload protection shall be provided by a limiter circuit, which monitors the amplifier output and reduces the input level to the amplifier should the amplifier output begin to clip.

The enclosure shall have a rectangular shape and shall incorporate two side handles, one on each side, and a top-mounted pole receptacle. The enclosure shall be constructed of multi-ply wood.

The active subwoofer loudspeaker system shall be the Mackie Designs SWA1501.

## Frequency Response

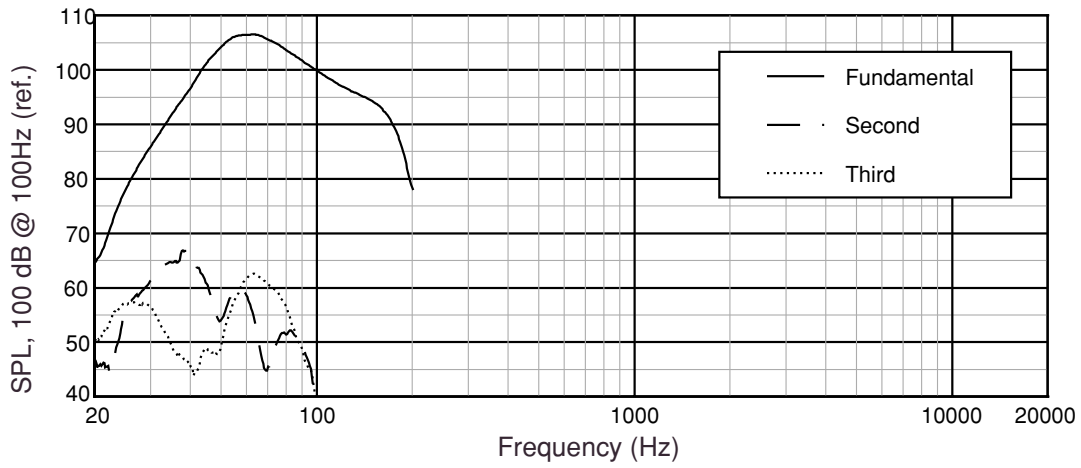

## Dimensions

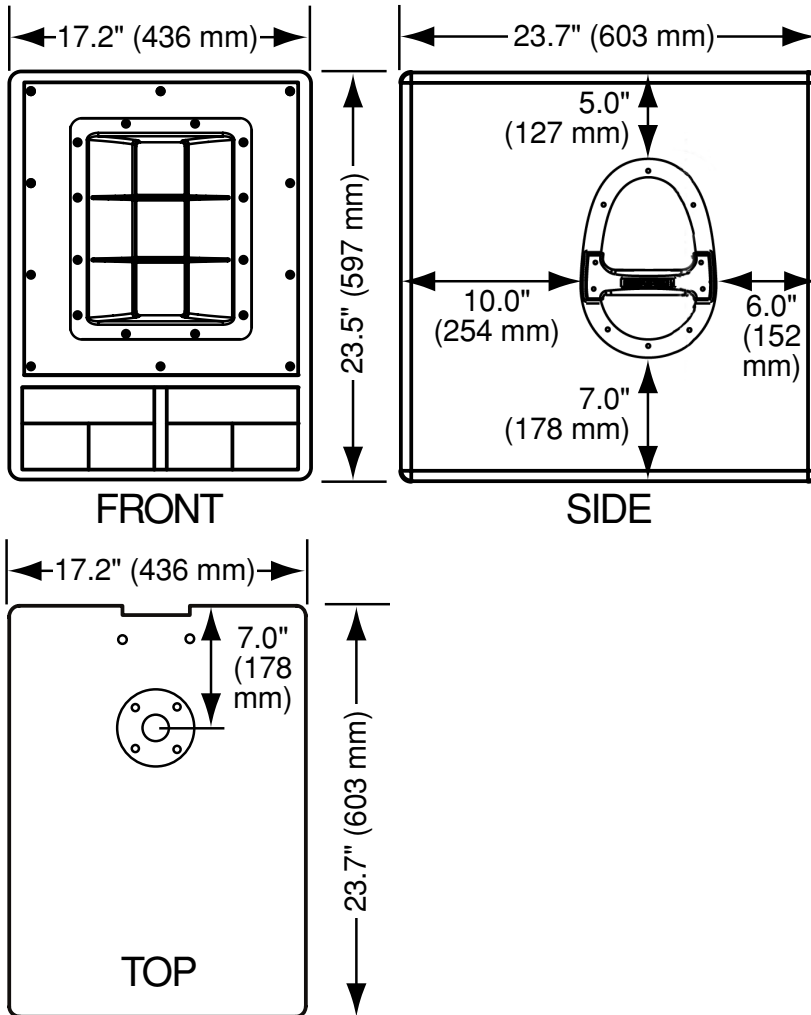



*Some of the  
people at our  
factory who helped  
design, build, sell,  
and support your  
product.*

**MACKIE®**

Mackie Designs Inc.

16220 Wood-Red Rd. NE • Woodinville, WA 98072 • USA  
US & Canada: 800/898-3211

Europe, Asia, Central & South America: 425/487-4333

Middle East & Africa: 31-20-654-4000

Fax: 425/487-4337 • [www.mackie.com](http://www.mackie.com)

E-mail: [sales@mackie.com](mailto:sales@mackie.com)